

Static Analysis Techniques for Testing Application Security

OWASP Boulder

August 21st, 2008

Dan Cornell – dan@denimgroup.com

Agenda

- What is Application Security?
- What is Static Analysis?
 - *Static versus Dynamic*
 - *Overview*
- Different Approaches
- Examples of Static Analysis Tools
 - *FindBugs (Java)*
 - *PMD (Java)*
 - *FxCop (.NET)*
 - *XSSDetect (.NET)*
- Process Implications
- Questions

What is Application Security?

- Ensuring that applications behave as expected under the entire range of possible inputs
- Really a subset of software correctness/QA – however...
- More typically focused on what an application is NOT supposed to do rather than what it IS supposed to do

Software Implementation – Perfect World

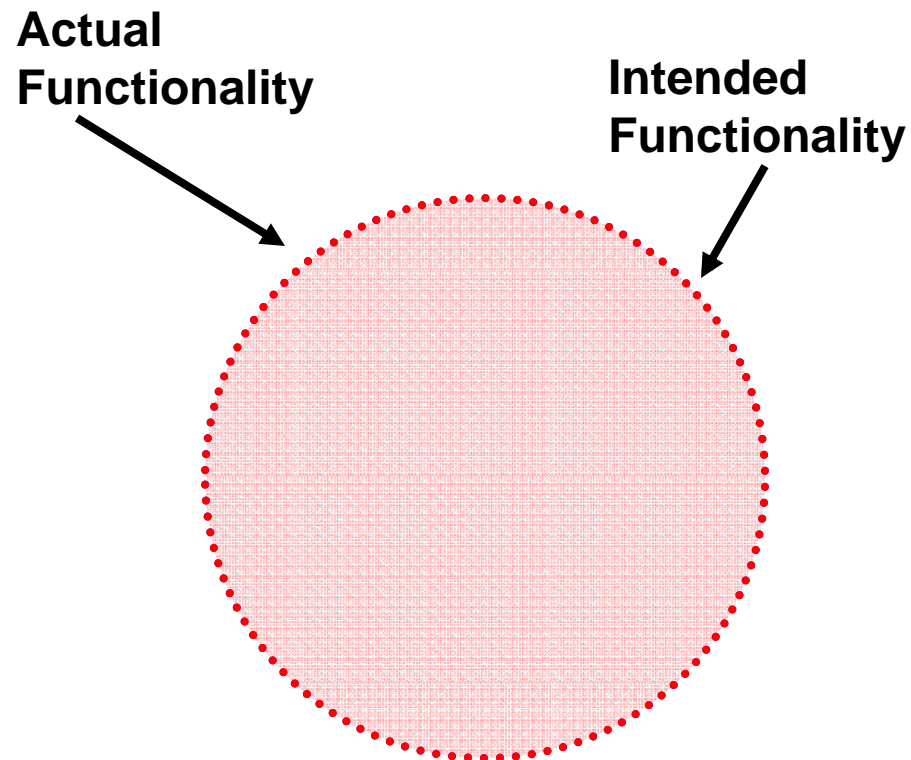

Software Implementation – Real World

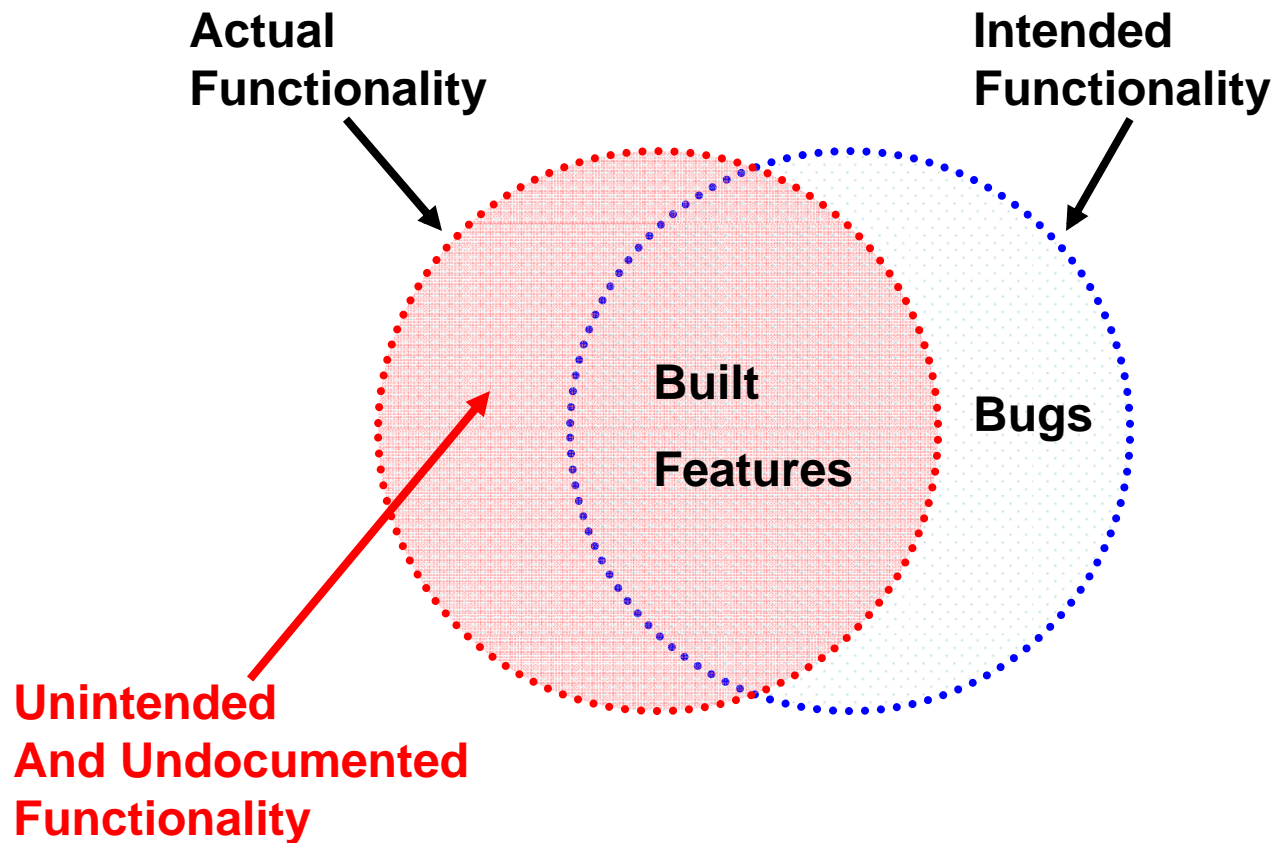

How Not To Do It

- Q: What are you all doing to address application security concerns in your organization?
- A: We bought “XYZ Scanner”
- Q: Okay... Are you actually using it?
- A: We ran some scans
- Q: And how did *that* go?
- A: Oh we found some stuff...
- Q: How did you address those issues?
- A: I think we sent the report to the developers. Not sure what they did with them. I guess I ought to check in on that...

What is Static Analysis?

- Analyzing software artifacts in order to gain information about the software
 - *Source code*
 - *Binaries*
 - *Configuration files*
- Analyzing software “at rest”
- Also called “white box testing” and “source code review”
- PLEASE NOTE: Unless otherwise discussed, Static Analysis will refer to Static Analysis being performed by an automated tool

Dynamic Analysis

- Examining running software to see how it behaves under different stimuli
 - *Analyzing request and response patterns*
 - *Checking remotely-detectable configuration settings*

Which to Use?

- Static Analysis
 - *Advantages*
 - *Disadvantages*
- Dynamic Analysis
 - *Advantages*
 - *Disadvantages*
- Actually Making a Decision

Static Analysis Advantages

- Have access to the actual instructions the software will be executing
 - *No need to guess or interpret behavior*
 - *Full access to all of the software's possible behaviors*

Static Analysis Disadvantages

- Require access to source code or at least binary code
 - *Typically need access to enough software artifacts to execute a build*
- Typically require proficiency running software builds
- Will not find issues related to operational deployment environments

Dynamic Analysis Advantages

- Only requires a running system to perform a test
- No requirement to have access to source code or binary code
- No need to understand how to write software or execute builds
 - *Tools tend to be more “fire and forget”*
- Tests a specific, operational deployment
 - *Can find infrastructure, configuration and patch errors that Static Analysis tools will miss*

Dynamic Analysis Disadvantages

- Limited scope of what can be found
 - *Application must be footprinted to find the test area*
 - *That can cause areas to be missed*
 - *You can only test what you have found*
- No access to actual instructions being executed
 - *Tool is exercising the application*
 - *Pattern matching on requests and responses*

Dynamic, Static and Manual Testing

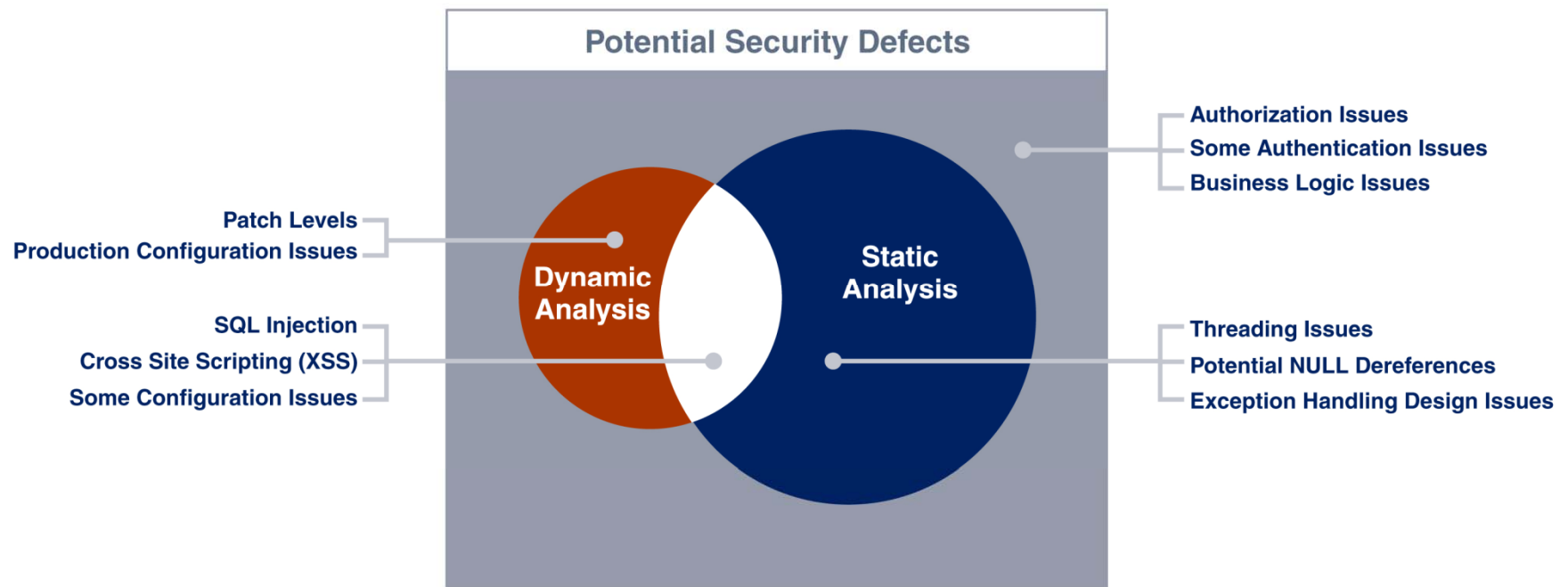

Actually Making a Decision

- No access to source or binaries? **Dynamic**
- Not a software developer, don't understand software builds? **Dynamic**
- Performing a “pen test” or other test of an operational environment? **Dynamic**
- None of the previous problems? **Static**
- Really want to do the job right? **Both (and then some...)**

Actually Making a Decision

- In our experience:
- **Information Security** practitioners are more comfortable with the Dynamic Analysis tools
 - *Analog to scanners such as Nessus or ISS*
- **Software Development** practitioners are comfortable with both Static and Dynamic Analysis tools, but can get the most value out of Static Analysis tools
 - *More complete view of the software*
 - *Integration with IDEs is a plus*
- Understand that there are things that tools can find, and things tools can't find. **Running a tool doesn't make you "secure"**

Overview

- General Approach
- Source or Binary?

General Approach

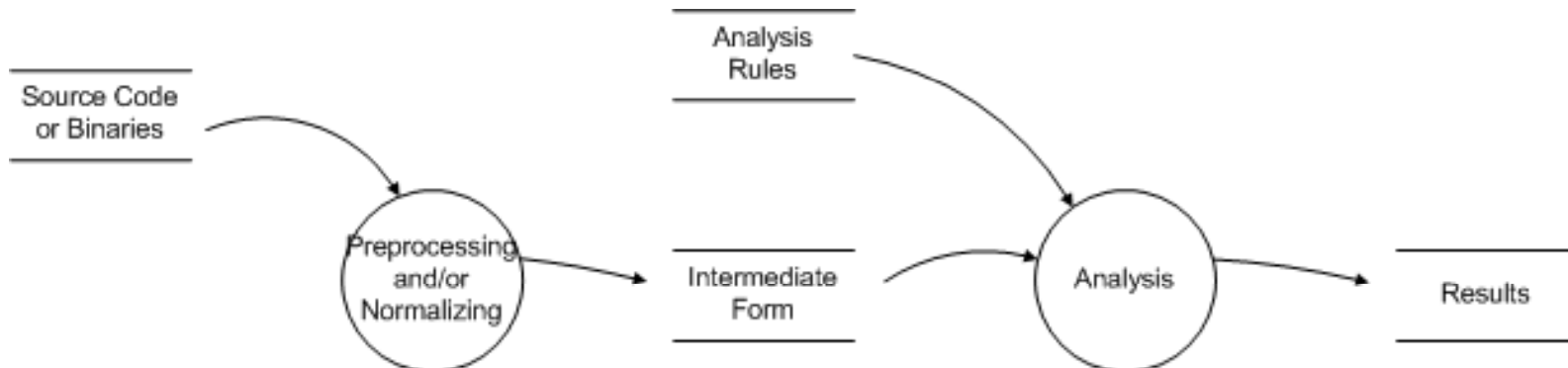

Source or Binary?

- Access to source typically provides more information to the analysis tool than only having access to the binaries
- Advantages of binaries:
 - *More commonly available*
 - *If you dynamically generate binaries based on database schema, etc*

Source or Binary – C/C++

- “Vanilla” C can be reasonably easy to decompile, but...
- C++ and C compiled with compiler optimizations can be challenging to decompile sensibly

Source or Binary – Java or .NET

- These environments are pretty easy to decompile
 - *“Source” recovery is typically pretty easy*
- Most .NET tools actually use binaries and disassemble them into IL
 - *Thus they only have to have one parser to process IL rather than one for every .NET language*

Different Approaches

- Increasing the scope of analysis increases the capability of the tool to find potential errors
- As scope increases, tools must either effectively prioritize analysis options or risk having excessive runtimes

Scope and Capability

Scope of Analysis versus Capability of Tool

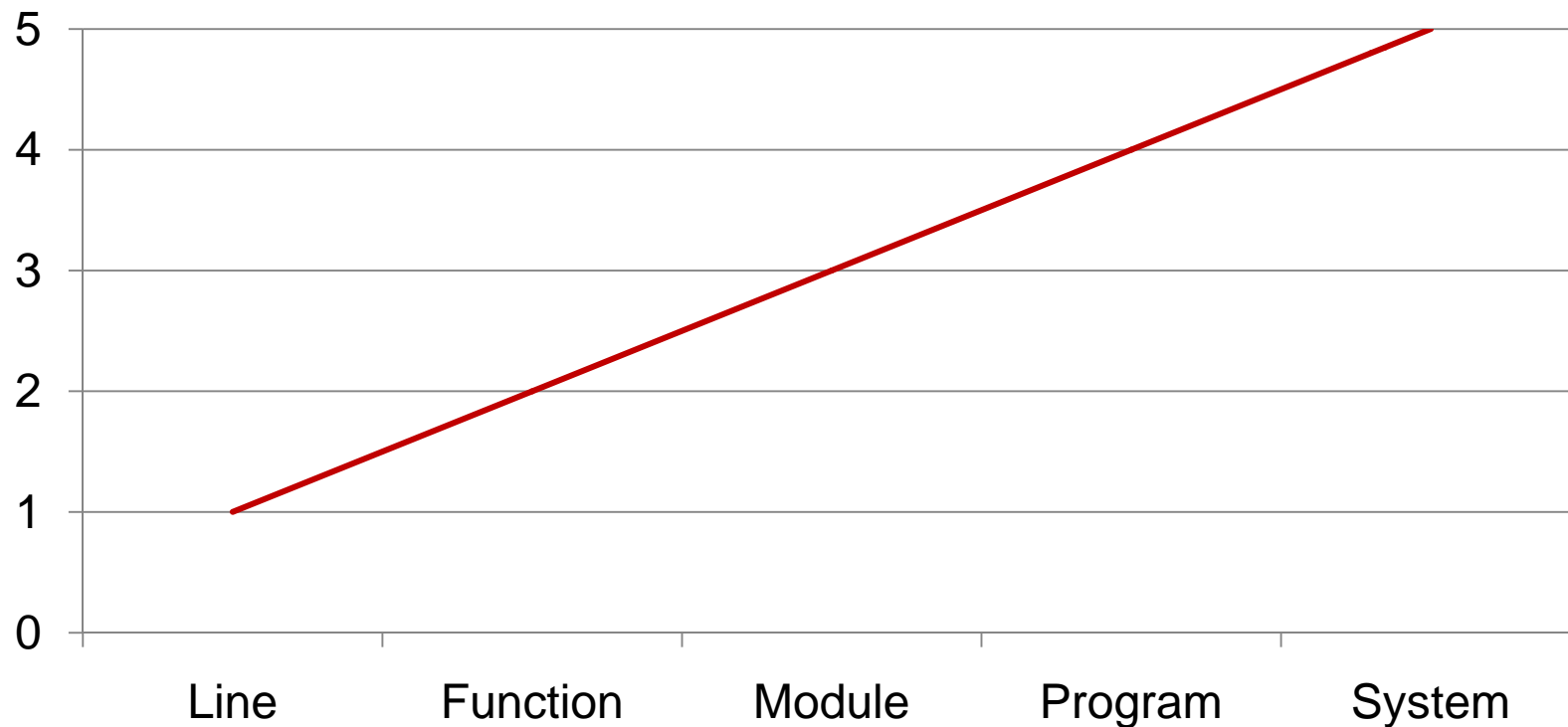

Line Focus

- Like using “grep” to identify banned or suspect function calls
- This was the approach taken by early tools
- Good way to make a quick pass for potential vulnerabilities
 - *Good for targeting manual review*
- Challenging to use on large codebases
- The more “signatures” that are included, the higher the noise to signal ratio will be
 - *Just looking for specific functions*

Line Focus Example

- Rule: gets() is BAD

- Input:

```
my_str = gets();
```

- Result: Flag this line for review
- Pretty basic, but better than nothing

Line Focus: C/C++

- Known “bad” APIs:
 - *strcpy()*
 - *gets()*
 - *scanf()*
 - *sprintf()*

Line Focus: Java

- SQL injection
 - *[Connection].createStatement()*
- XSS
 - *<%=*
- More general parameter tampering:
 - *[HttpServletRequest].getParameter()*
 - *[HttpServletRequest].getParameterValue()*
 - *[HttpServletRequest].getCookies()*
 - *[HttpServletRequest].getHeader()*

Line Focus: .NET

- SQL Injection:
 - *SqlCommand*
- XSS
 - *<%=*
- More general parameter tampering
 - *Request[*
 - *Request.Cookies[*
 - *Request.Headers[*

Two (Crappy) Scripts I Wrote

- dotnetcheck.sh and javacheck.sh
- Implement the checks I mentioned above

Function and Module Focus

- At this point the tool needs to be acting as a compiler
 - *Parse into tokens, determine lexical structure*
- This allows for much more sophisticated analysis
 - *State machines*
 - *Control flow*
 - *Data flow*

Function and Module Focus Example

- Rule: Memory should only be freed once

- Input:

```
void f()  
{  
    my_mem = malloc(256);  
    free(my_mem);  
    free(my_mem);  
}
```

- Result:

- *my_mem is marked as allocated*
- *my_mem is marked as freed*
- *Flag the second call to free(my_mem) as an issue*

Program and System Focus

- Expanding the scope of inquiry allow tools to find more and more subtle flaws
- Also helps avoid false positives

Dataflow and Taint Tracking

- Track dataflows through the system
 - *Sources and Sinks*
- Attach taint flags to inputs
 - *Web parameters and cookies*
 - *Data read from files*
 - *Environment variables*
 - *Data read from databases*
 - *Data read from web services*
- What type of taint?
 - *From the network*
 - *From a configuration setting*
 - *From a database*
 - *And so on*
- Identify “cleaning” functions

Taint Sources and Sinks for a Web Application

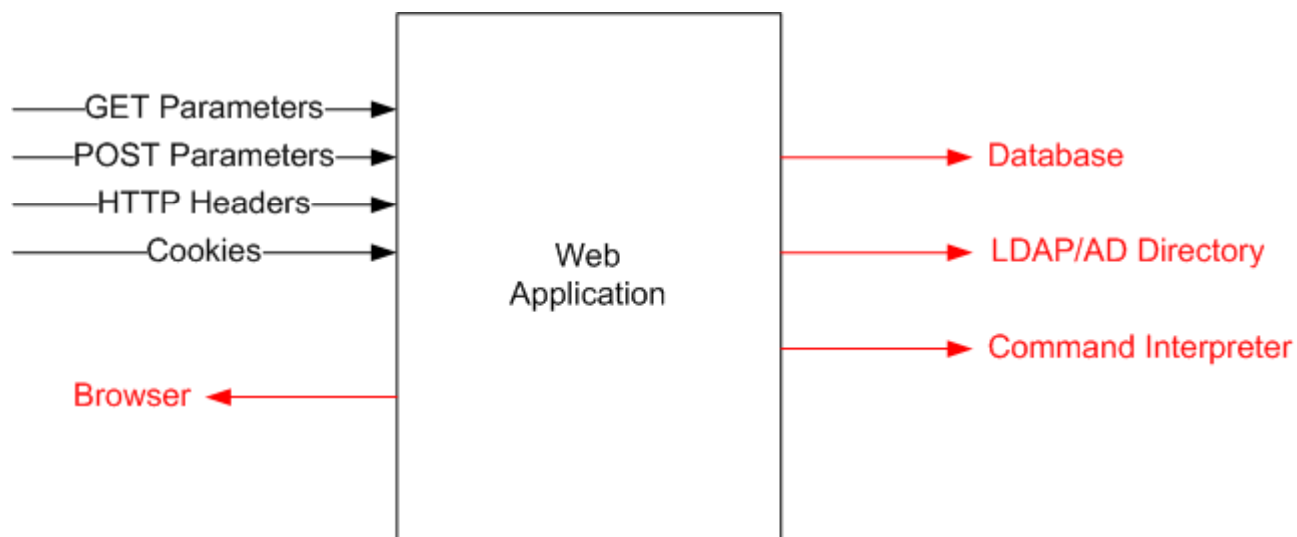

Taint Sources and Sinks for an SUID Root Binary

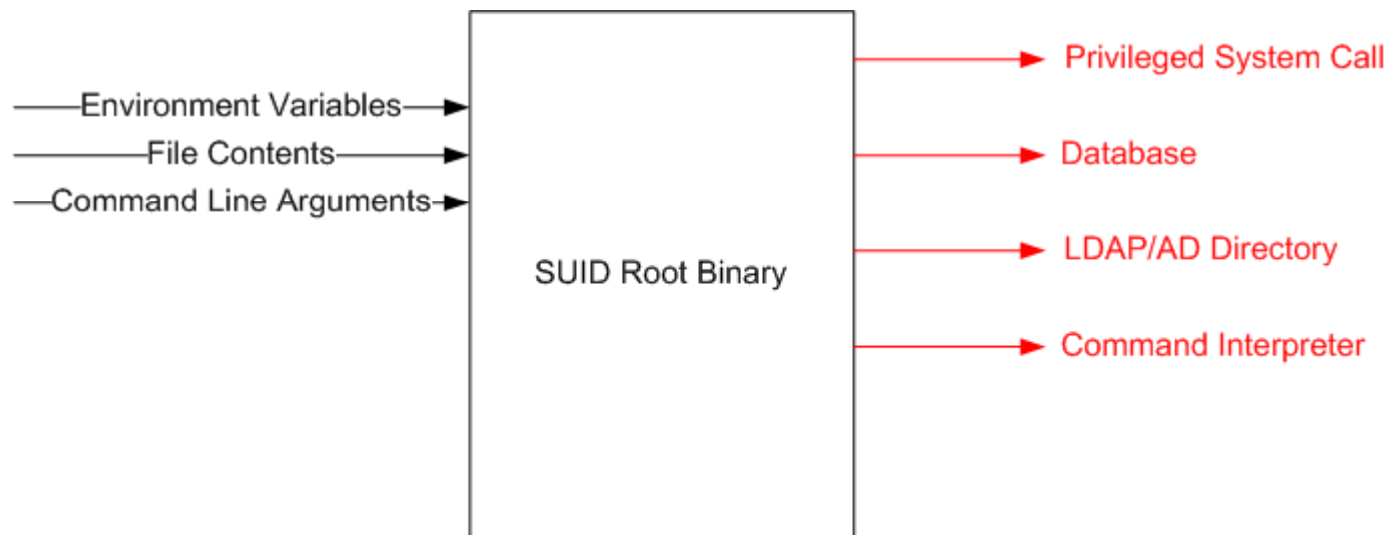

Program and System Focus Example

- Rule:
 - *User-supplied data should never be included in a SQL query without being properly escaped*

Program and System Focus Example (continued)

- **Input:**

```
public void doGet(HttpServletRequest req, HttpServletResponse resp)
{
    String user = req.getParameter("username");
    logStuff(user, "my_page");
    //    Render out HTML...
}
```

```
private logStuff(String user, String location)
{
    Connection con = getConnection();
    Statement stmt = con.createStatement();
    String sql
        = "INSERT INTO log (user, location) VALUES ('" + user + "', '" + location + "'"
    stmt.executeUpdate(sql);
}
```

Program and System Focus Example (continued)

- Result:
 - *Input from `getParameter()` call is marks user variable as tainted (Source)*
 - *Flow of data is traced into the `logStuff()` method*
 - *sql variable is also marked as tainted when it is concatenated with username parameter*
 - *`executeUpdate()` is marked as a security issue because it received tainted data (Sink)*

Examples of Static Analysis Tools

- FindBugs (Java)
- PMD (Java)
- FxCop (.NET)
- XSSDetect (.NET)

FindBugs (Java)

- Java-based static analysis tool
- LGPL-licensed
- Originally developed by Dr. Bill Pugh from the University of Maryland
- Intended to find correctness issues, also identifies some security issues

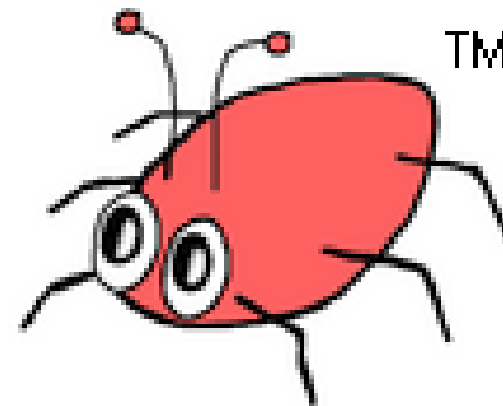

findbugs.sourceforge.net

PMD (Java)

- Java-based static analysis tool
- BSD-licensed
- Lead developers are David Dixon-Peugh and Tom Copeland
- Intended to find correctness and complexity issues, also finds some security issues

pmd.sourceforge.net



FxCop (.NET)

- Microsoft-provided tool for .NET static analysis
- Freely available
- Enforces coding standards (variable naming, etc)
- Similar to FindBugs in its security capabilities

Original URL:

<http://www.microsoft.com/downloads/details.aspx?FamilyID=9aea970-f281-4fb0-aba1-d59d7ed09772&DisplayLang=en>

Tiny URL: <http://tinyurl.com/67qoda>

XSSDetect (.NET)

- Microsoft-provided tool for .NET static analysis
- Freely available (BETA!)
- Performs data flow analysis to identify Cross Site Scripting (XSS) defects

blogs.msdn.com/ace_team/archive/2007/10/22/xssdetect-public-beta-now-available.aspx

- Based on the Microsoft Research Phoenix framework
 - *For software analysis and optimization*
 - research.microsoft.com/phoenix/

Limitations

- Static Analysis tools are a **starting point** for code review. **Not a complete solution.**
- Static Analysis tools (like all automated tools) do not understand what your application is supposed to do
 - *Out of the box rules are for general classes of security defects*
 - *Applications can still have issues with authorization and other trust issues*
 - *Only cover 50% of security defects (Dr. Gary McGraw)*
- False positives can be time consuming to address
- Solutions?
 - *Custom rules can help to add some application specific context*

Process Implications

- Static Analysis tools can provide tremendous benefits
- It is easier to start a new project using a tool than to impose one on an existing system
- I have found that using a Static Analysis tool while developing helps to improve my coding skills
 - *Immediate feedback when mistakes are made*
 - *Learn more about language and platform internals*

Process Implications: Questions

- Who is going to run the tool?
- When is the tool going to be run?
- What will be done with the results?

- Until you can answer these questions, you should not assume that a Static Analysis tool will help you improve security

Additional Resources

- Book: Secure Programming With Static Analysis (Brian Chess and Jacob West)
- Blog: Microsoft Code Analysis and Code Metrics Team Blog
 - blogs.msdn.com/fxcop/
- Website: FindBugs publications page
 - findbugs.sourceforge.net/publications.html
- Various commercial vendors...

Questions

Dan Cornell - dan@denimgroup.com

(210) 572-4400

Website: www.denimgroup.com

Blog: denimgroup.typepad.com